

# PI 350/500 AC/DC

---

Reservedelsliste

Spare parts list

Ersatzteilliste

Liste des pièces de rechange



**MICATRONIC**  
WELDING VALUE

50115044 A Valid from 2024 week 03

# PI 350/500 AC/DC

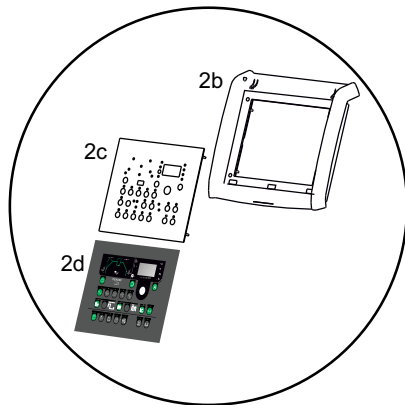

Pos.	No.	Varebetegnelse Warenbezeichnung	Description of goods Désignation des pièces
1	45050315	Panellåge Deckelverschlußklappe	Front panel cover Protection du panneau avant
2a	76117067	Elektronikboks Elektronikbox	Control box Boîtier de commande
2b	45050345	Front uden folie Vorderseite ohne Folie	Front without foil Face avant sans feuille
2c	70210663	Forplade (elektronikboks) Frontplatte (Elektronikbox)	Front plate (control box) Plaque avant (boîtier de commande)
2d	61113525	Folie til front Folie für Vorderseite	Foil for front Face avant de feuille
3	18503605	Knap ø28 Knopf ø28	Button ø28 Bouton ø28
3	18521208	Dæksel til knap ø28 Deckel für den Knopf ø28	Cover for button ø28 Couvercle de bouton ø28
4	45050319	Greb handgriff	Handle Poignée
5	61113834	Front PI Frontplatte PI	Front panel PI Pièce avant PI
6	17110015	Afbryder, vandtæt Schalter, wasserdicht	Switch, waterproof Interrupteur, étanche à l'eau
7	74471300	Ledningssæt med 7-polet stik, Leitungssatz mit Stecker 7-polig	Wire harness with 7-pole plug Jeu de câbles avec prise 7-pôle
8	43120007	Lynkobling til gas Schnellkupplung, Gas	Quick release fitting, gas Unité d'accouplement rapide gaz
9	61113836	Sideskærm, højre Seitenschirm, rechts	Side panel, right Plaque latérale droite
10	18110008	TIG-tilslutning, komplet WIG Zentralanschluß komplett	TIG central adaptor complete Raccord ZA TIG complet
11	18110002	Dinsebøsning Dinsebuchse	Dinse coupling socket Douille de raccordement, type Dinse

# PI 350/500 AC/DC

---

Pos. No.	Varebetegnelse Warenbezeichnung	Description of goods Désignation des pièces
12a 43129007	Lynkoblingssæt rød m/ventil, 8mm Anschlußsatz rot mit Ventil, 8mm	Quick adaptor set red with valve, 8mm Jeu d'accouplement rapide rouge avec valve, 8mm
12b 43129008	Lynkoblingssæt blå m/ventil, 8mm Anschlußsatz blau mit Ventil, 8mm	Quick adaptor set blue with valve, 8mm Jeu d'accouplement rapide bleu avec valve, 8mm
13 44220125	Drejehjul Rad, drehbar	Swivelling wheel Roue pivotante
14a 45050316	Hjørne til skærm Ecke	Corner Angle plastique
14b 40840514	Skrue M5x14mm Schraube M5x14mm	Screw M5x14mm Vis M5x14mm
14c 41319023	Lang skærmclips M5 for gevind reparation Langer Clip M5 (für Reparatur des Gewindes)	Long clip M5, (for repairment of thread) Attache M5 (pour réparation du fil)
15 70613680	Brænderholder Brennerhalter	Welding torch holder Support torche
16 61113835	Sideskærm, venstre Seitenschirm, links	Side panel, left Plaque latérale gauche
17 45050317	Gælle Lüftungsslitz	Gill Profilé
18 70613638	Vogn Wagen	Trolley Chariot
19 44210253	Endenavshjul Nabenrad	Wheel Roue d'extrémité moyeu
20 44610001	Navkapsel Nabendeckel	Wheel cap Couvre-moyeu

# PI 350/500 AC/DC

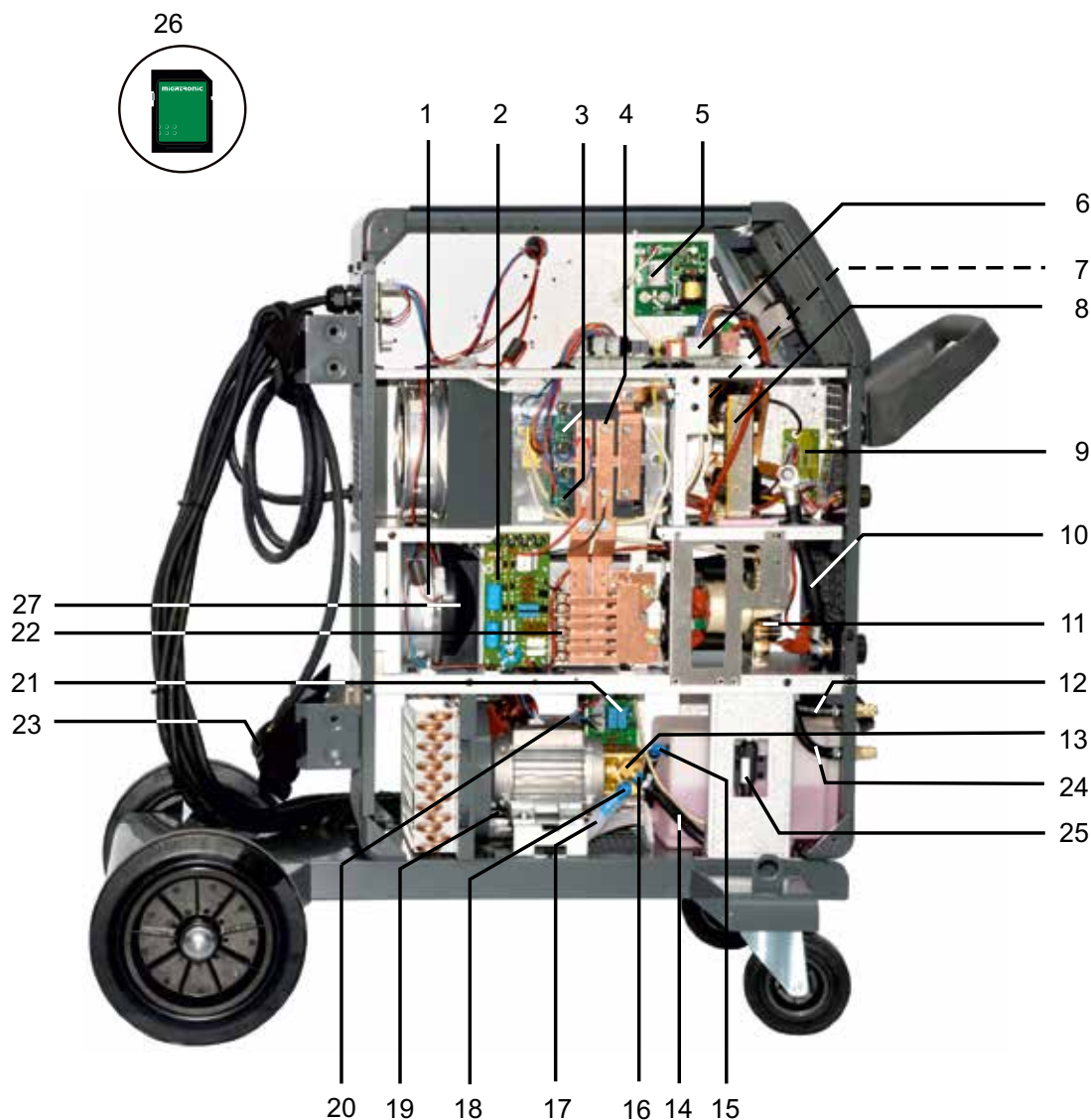

Pos.	No.	Varebetegnelse Warenbezeichnung	Description of goods Désignation des pièces
1a	73940200	Ventilator PI 350 (gældende fra 01.06.2012) Lüfter PI 350 (gültig ab 01.06.2012)	Fan PI 350 (Valid from 01.06.2012) Ventilateur PI 350 (Valable à partir de 01.06.2012)
1b	17300042	Ventilator PI 350 (gældende før 01.06.2012) Lüfter PI 350 (gültig bevor 01.06.2012)	Fan PI 350 (Valid before 01.06.2012) Ventilateur PI 350 (Valable avant de 01.06.2012)
1c	17300042	Ventilator PI 500 Lüfter PI 500	Fan PI 500 Ventilateur PI 500
2	71617054	Snubber print Snubberplatine	Snubber PCB Carte de circuits imprimés pour filtrage des sommets de courant
3	71617010	Connector-print Connector-Print	Connector print Carte circuit imprimé
4	73250025	IGBT, AC-modul IGBT, AC-Modul	IGBT, AC-module IGBT, module CA
5	71617011	HF-print HF Platine	HF PCB Carte de circuits imprimés HF
6	71617053	Styreprint, AC-modul Steuerplatine, AC-Modul	Control PCB, AC module Circuit imprimé de module CA
7	16170021	Strømsensor Stromsensor	Current sensor Detecteur de courant
7a	74471258	Ledningssæt, strømsensor Leitungssatz, Stromsensor	Wire harness, current sensor Filerie, detecteur de courant

# PI 350/500 AC/DC

Pos.	No.	Varebetegnelse Warenbezeichnung	Description of goods Désignation des pièces
8a	16160157	HF-transformator PI 350 ( <i>gældende fra 01.06.2012</i> ) Trafo HF PI 350 ( <i>gültig ab 01.06.2012</i> )	Transformer HF PI 350 ( <i>Valid from 01.06.2012</i> ) Transformateur HF PI 350 ( <i>Valable à partir de 01.06.2012</i> )
8b	16160142	HF-transformator PI 350 ( <i>gældende før 01.06.2012</i> ) Trafo HF PI 350 ( <i>gültig bevor 01.06.2012</i> )	Transformer HF PI 350 ( <i>Valid before 01.06.2012</i> ) Transformateur HF PI 350 ( <i>Valable avant de 01.06.2012</i> )
8c	16160142	HF-transformator PI 500 Trafo HF PI 500	Transformer HF PI 500 Transformateur HF PI 500
9	71617055	Dinseprint Platine, Dinsebuchse	PCB, dinse coupling socket Circuit imprimé de fiche dix
10	74227019	Kabel 0,18m, 70mm <sup>2</sup> Kabel 0,18m, 70mm <sup>2</sup>	Cable 0,18m, 70mm <sup>2</sup> Câble 0,18m, 70mm <sup>2</sup>
11a	16413421	Drosselmodul PI 350	Inductor module PI 350
11b	16413416	Drosselmodul PI 500	Inductor module PI 500
12	74124555	Slange 550mm Schlauch 550mm	Hose 550mm Tuyau 550mm
13	43620024	Vinkel ¼", messing Winkel ¼", Messing	Angle ¼", brass Angle de laiton ¼"
14	74124526	Slange 260mm Schlauch 260mm	Hose 260mm Tuyau 260mm
15	43350004	Vinkelslangesamler lige, ø8 plast Winkelschlauchverbinder gerade ø8, Plast	Angle hose connector straight ø8, plastic Raccord d'extrémité, angle ø8, plastic
16	43350007	Slangenippel lige, ø8x1/4", plast Schlauchnippel gleich ø8x1/4", Plast	hose nipple straight ø8x1/4", plastic Raccord d'extrémité ø8x1/4" plastic
17	74120083	Sugeslange, 230mm Saugschlauch, 230mm	Suction hose, 230mm Tuyau de suction, 230mm
18	43350006	Vinkelslangenippel ø12x1/4", plast Winkelschlauchnippel ø12x1/4", Plast	Angle hose nipple ø12x1/4", plastic Raccord d'extrémité, angle ø12x1/4", plastic
19	74124542	Slange 420mm Schlauch 420mm	Hose 420mm Tuyau 420mm
20	74471256	Ledningssæt, vandmodul Leitungssatz, Kühlmodul	Wire harness, cooling unit Jeu de câble, module de refroidissement
21a	71613482	Print uden flow kontrol Platine ohne Flowkontrolle	PCB without flow control Circuit imprimé sans contrôle du debit
21b	71613479	Print med flow kontrol Platine mit Flowkontrolle	PCB with flow control Circuit imprimé avec contrôle du debit
22	12220209	Udgangsdiode Ausgangsdiode	Output rectifier Diode
23	70220009	Flaskerem Gürtel für Gasflasche	Belt for gas cylinder Ceinture
24a	74124522	Slange 220mm (med flowkontrol) Schlauch 220mm (mit Flowkontrolle)	Hose 220mm (with flow control) Tuyau 220mm (avec contrôle du debit)
24b	74124526	Slange 260mm (uden flowkontrol) Schlauch 260mm(ohne Flowkontrolle)	Hose 260mm(without flow control) Tuyau 260mm(sans contrôle du debit)
25	17130103	Flow kontrol Durchflußkontrolle	Flow switch Contrôle du debit
26	78861297	SD hukommelseskort – SW opdatering SD memory card – Softwareaufgradieren	SD memory card – software update SD memory card - mise à jour logicielle
27	45050296	Venturi for køleprofil Venturi für Kühlprofil	Venturi for cooling profile Venturi pour profil de refroidissement

# PI 350/500 AC/DC

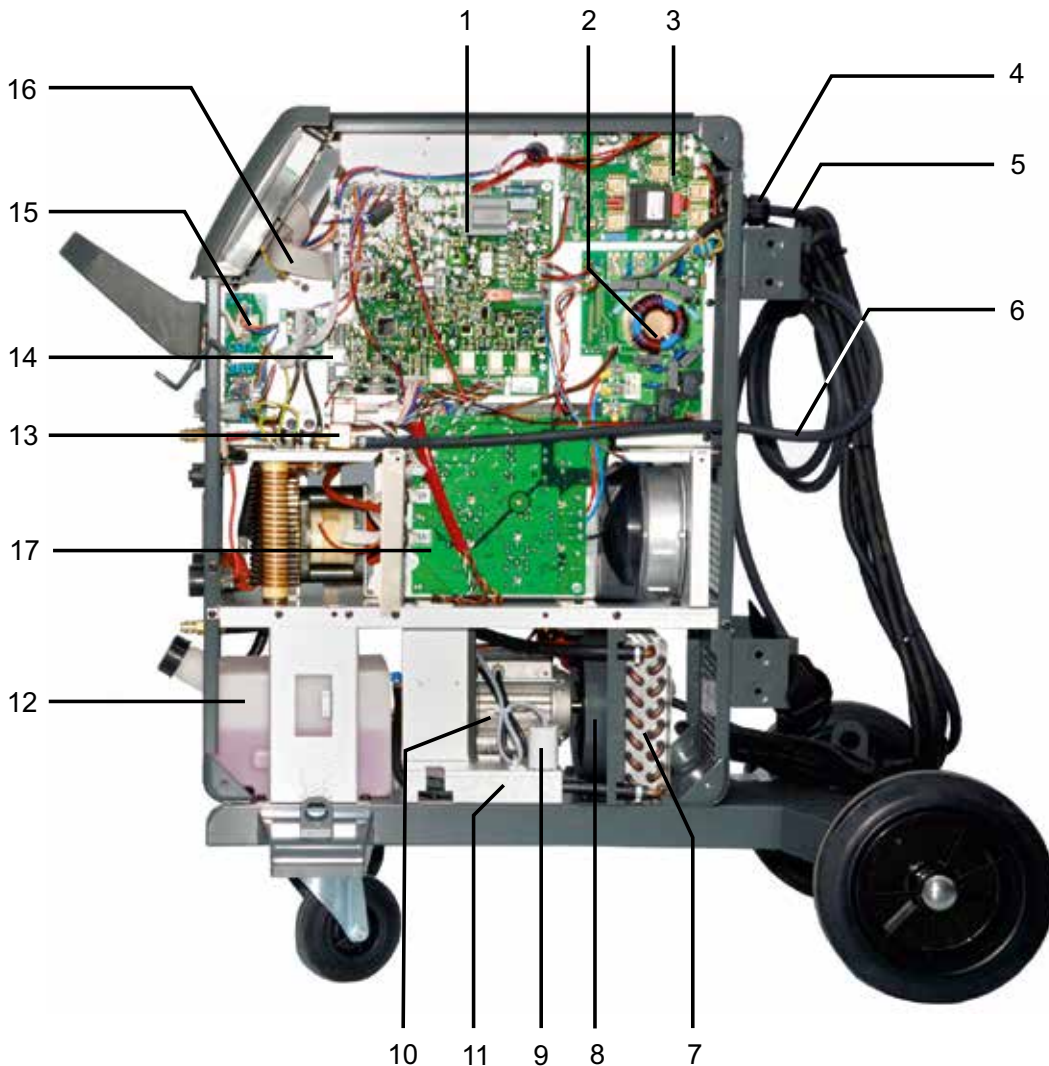

Pos.	No.	Varebetegnelse Warenbezeichnung	Description of goods Désignation des pièces
1a	71617063	Styreprint Steuerplatine	Control PCB Carte circuit imprimé
1b	11613605	Programmeringsenhed (PLD) PI 350 Programmierbarer Logikbaustein PI 350	Programmable logical device (PLD) PI 350 PLD (Programmable logical device) PI 350
1c	11613609	Programmeringsenhed (PLD) PI 500 Programmierbarer Logikbaustein PI 500	Programmable logical device (PLD) PI 500 PLD (Programmable logical device) PI 500
2	71613486	Netfilter print Netzfilter Platine	Mains filter Circuit imprimé filter éliminateur
3a	71617068	Print, Power Supply Unit Platine, Stromversorgungseinheit	PCB, Power Supply Unit Circuit imprimé, Power Supply
3b	17173025	Sikring 2,5A, træg Sicherung 2,5A træg	Fuse 2.5A, slow Fusible 2,5A lent
3c	17175020	Sikring 2A FF 700Vac Sicherung 2A FF 700Vac	Fuse 2A FF 700Vac Fusible 2A FF 700Vac
4.1	18480021	Kabelforskrning PI 350 Kabelverschraubung PI 350	Cable screw connection PI 350 Manchon fileté de câble PI 350
4.2	18480019	Kabelforskrning PI 500 Kabelverschraubung PI 500	Cable screw connection PI 500 Manchon fileté de câble PI 500
4.2a	18480018	Møtrik til kabelforskrning PI 500 Mutter für Kabelverschraubung PI 500	Nut for cable screw connection PI 500 Ecrou pour manchon fileté de câble PI 500
5a	74234055	Netkabel 4x2,5 PI 350 Netzkabel 4x2,5 PI 350	Mains supply cable 4x2.5 PI 350 Câble d'alimentation 4x2,5 PI 350
5b	74234039	Netkabel 4x4,0 PI 500 Netzkabel 4x4,0 PI 500	Mains supply cable 4x4.0 PI 500 Câble d'alimentation 4x4,0 PI 500
6	74120090	Gasslange 2,5m Gasschlauch 2,5m	Gas hose 2.5m Tuyau de gaz 2,5m
7	71240015	Køler Kühler	Refrigerator Refrigerdisseur

# PI 350/500 AC/DC

Pos.	No.	Varebetegnelse Warenbezeichnung	Description of goods Désignation des pièces
8	70123697	Venturi Venturi	Venturi Venturi
9	15480500	Kondensator 5uF Kondensator 5uF	Condenser 5uF Condenseur 5uF
10	17310018	Vandpumpe 400Vac Wasserpumpe	Water pump 400Vac Pompe à eau
10a	44550166	Vinge, Umbra vandpumpe (gældende fra 01.10.2013)	Fan blade, Umbra water pump (valid from 01.10.2013)
		Lüfterflügel, Umbra Wasserpumpe (gültig ab 01.10.2013)	Hélice de ventilateur (Umbra) (valable à partir de 01.10.2013)
10b	44510166	Vinge, Speck vandpumpe (gældende før 01.10.2013)	Fan blade, Speck water pump (valid before 01.10.2013)
		Lüfterflügel, Speck Wasserpumpe (gültig bevor 01.10.2013)	Hélice de ventilateur (Speck) (valable avant de 01.10.2013)
11	24611509	Monteringsbeslag for vandpumpe Befestigung für Wasserpumpe	Mounting plate for water pump Console de montage de pompe à eau
12	45050287	Vandtank Wassertank	Water tank Réservoir à eau
13.1	78861238	Gaskit uden regulering Gaskit ohne Regelung	Gas kit without control Kit gaz sans régulateur
13.2	78861236	Gasreguleringskit Gasregelungs kit	Gas control kit Kit régulateur de gaz
13a	17230012	Magnetventil 24V DC 1/8" (78861238)	Solenoid valve 24V DC 1/8" (78861238)
		Magnetventil 24V DC 1/8" (78861238)	Solénoïde 24V DC 1/8" (78861238)
13b	17230013	Proportionalventil 24V DC 1/8" (78861236)	Proportional valve 24V DC 1/8" (78861236)
		Proportionalventil 24V DC 1/8" (78861236)	Solénoïde 24V DC 1/8" (78861236)
13c	43320031	Nippel ø6x1/8"	Hose nipple ø6x1/8"
		Schlauchstutz ø6x1/8"	Raccord d'extrémité ø6x1/8"
13d	43350009	Slangenippel ø4x1/8" plast Schlauchnippel ø4x1/8" Plast	Hose nipple ø4x1/8" plastic Raccord d'extrémité ø4x1/8" plastique
13e	71613715	Print gasregulering (78861236)	PCB gas control (78861236)
		Platine Gasregelung (78861236)	Circuit imprimé, kit régulateur de gaz (78861236)
13f	43120051	Nippel, push-in 1/8"x8mm Steckverschraubung 1/8"x8mm	Push-in fitting 1/8"x8mm Raccord d'extrémité, push-in 1/8"x8mm
14	74471258	Lednings sæt, strømsensor Leitungsbündel, Stromsensor	Wire harness, current sensor Filerie, détecteur de courant
15	71617048	HF filterprint HF Filterplatine	HF filter PCB Circuit imprimé de filtre HF
16	17200180	Fladkabel 26pol, 380mm Flachkabel 26 polig, 380mm	Flat cable 26-pole, 380mm Câble méplat, 26 brins, 380mm
17a	71613527	Powermodul PI 350	Power module PI 350
		Powermodul PI 350	Module de puissance PI 350
17b	71613523	Powermodul PI 500	Power module PI 500
		Powermodul PI 500	Module de puissance PI 500
	99290506	Migatronic grøn kølevæske, 5 liter Migatronic grüne Kühflüssigkeit, 5 Liter	Migatronic green coolant, 5 litres Liquide de refroidissement vert Migatronic, 5 litres

**Ekstra udstyr:**  
**Zusätzliche Ausrüstung:**

**Special equipment:**  
**Equipment spécial:**

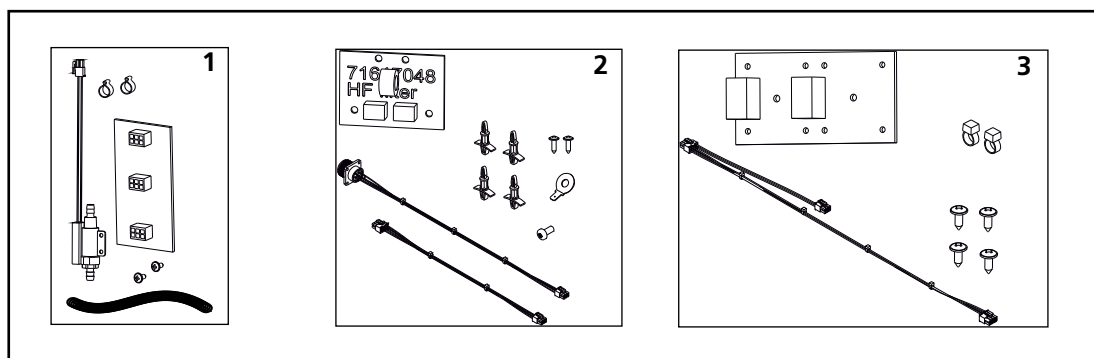

Pos.	No.	Varebetegnelse Warenbezeichnung	Description of goods Désignation des pièces
1	78861257	Kit vandkontrol Kit für Wasserkontrolle	Kit for water control Kit, contrôle d'eau
2	78861271	Fjernkontrolkit Fernreglerkit	Remote control kit Kit commande à distance
3.1	78861407	Kit, CAN-BUS PI 500 AC/DC	Kit, CAN-BUS PI 500 AC/DC
		Kit, CAN-BUS PI 500 AC/DC	Kit, CAN-BUS PI 500 AC/DC
3.2	78861408	Kit, CAN-BUS PI 350 AC/DC	Kit, CAN-BUS PI 350 AC/DC
		Kit, CAN-BUS PI 350 AC/DC	Kit, CAN-BUS PI 350 AC/DC

# Vogn med omkoblingsmodul/Trolley with unit for changeable voltage/ Fahrwagen mit Autotrafo/Chariot avec autotransformateur

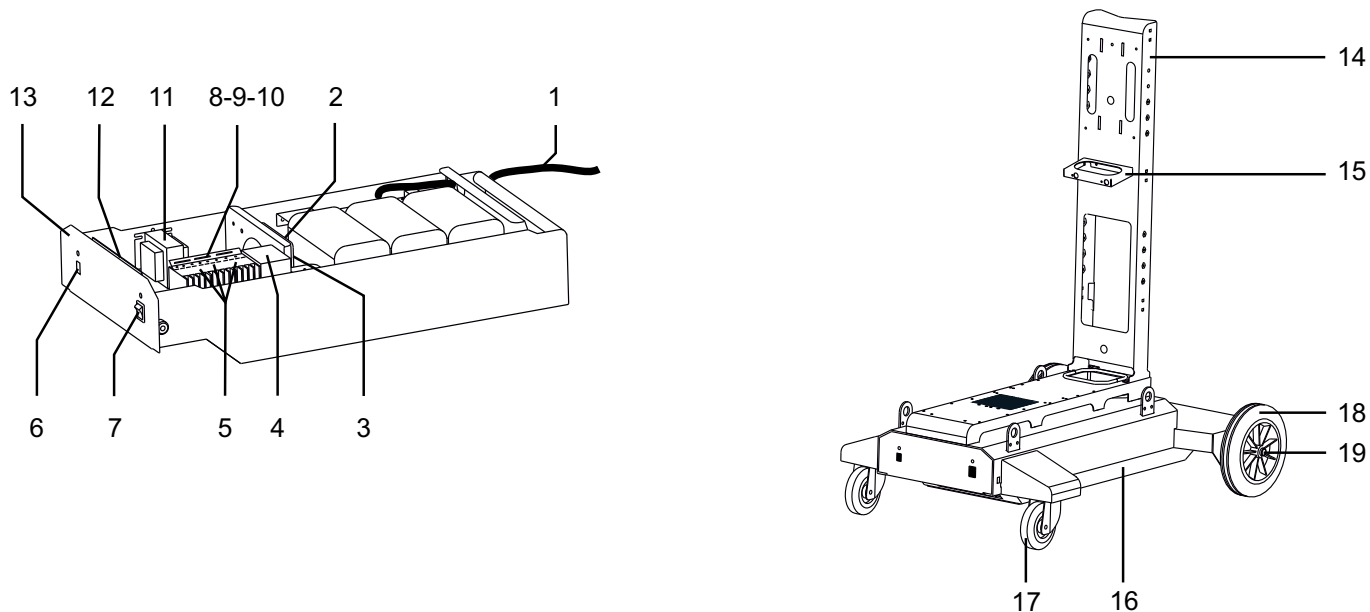

Pos.	No.	Varebetegnelse Warenbezeichnung	Description of goods Désignation des pièces
	78861190	Autotrafo, komplet Autotrafo, komplett	Autotransformer, complete Autotransformateur, complet
1	74234002	Netkabel 8,5m 4x6mm <sup>2</sup> Netzkabel 8,5m 4x6mm <sup>2</sup>	Mains supply cable 8,5m 4x6mm <sup>2</sup> Câble d'alimentation 8,5m 4x6mm <sup>2</sup>
2	17300043	Ventilator Lüfter	Fan Ventilateur
3	71613604	Print til autotrafo Platine für autotrafo	PCB for autotransformer Circuit imprimé, autotransformateur
4	17140020	Kontaktor 40 A Kontaktor 40 A	Contacteur 40 A Commutateur 40 A
5	17140019	Kontaktor 25 A Kontaktor 25 A	Contacteur 25 A Commutateur 25 A
6	17110101	Trykknop Druckknopf	Press button Pousse-bouton
7	17110015	Vippeafbryder 0-1 Kippschalter 0-1	Switch 0-1 Interrupteur 0-1
8	24540048	Strømskinne 1 Stromschiene 1	Current guide 1 Guide courant 1
9	24540049	Strømskinne 2 Stromschiene 2	Current guide 2 Guide courant 2
10	24540050	Strømskinne 3 Stromschiene 3	Current guide 3 Guide courant 3
11	16160119	Trafo 230-400-440-500 V og 24 V Trafo 230-400-440-500 V und 24 V	Transformer 230-400-440-500 V and 24 V Transformateur 230-400-440-500 V et 24 V
12	78861247	Print-kit Platine-Bausatz	PCB kit Circuit imprimé
13	70613613	Skuffe til autotrafo Schubkasten für Autotrafo	Drawer for autotransformer Tiroir pour autotransformateur
	18360001	Printpladeholder Printräger	Holder for circuit board Support pour circuit imprimé
	74471070	Ledningssæt Leitungsbündel	Wire harness Filerie
14	70613644	Søjle Säule	Column Colonne
15	70613672	Beslag for sammenspænding Beschlag für Zusammenspannen	Fitting for assembling Garniture d'assemblage
16	70613670	Svejst vogn Geschweißte Wagen	Welded trolley Chariot soudé
17	44220125	Drejehjul Rad, drehbar	Swivelling wheel Roue pivotante
18	44210253	Endenavshjul Nabenrad	Wheel Roue d'extrémité moyen
19	44610001	Navkapsel Nabendeckel	Wheel cap Couvre-moyeu





## DENMARK:

### Main office

#### **MIGATRONIC A/S**

Aggersundvej 33, DK-9690 Fjerritslev, Denmark  
Tel. +45 96 500 600, [www.migatronicon.com](http://www.migatronicon.com)

#### **MIGATRONIC AUTOMATION A/S**

Knøsgårdvej 112, DK-9440 Aabybro, Denmark  
Tel. +45 96 96 27 00, [www.migatronicon-automation.com](http://www.migatronicon-automation.com)

## MIGATRONIC EUROPE:

### Great Britain

#### **MIGATRONIC WELDING EQUIPMENT LTD**

1 Sarah Court, Armthorpe  
GB-Doncaster DN3 3FD, Great Britain  
Tel. +44 01509/267499, [www.migatronicon.com](http://www.migatronicon.com)

### France

#### **MIGATRONIC EQUIPEMENT DE SOUDURE S.A.R.L.**

Parc Avenir II, 313 Rue Marcel Merieux  
FR-69530 Brignais, France  
Tel. +33 04 78 50 65 11, [www.migatronicon.com](http://www.migatronicon.com)

### Italy

#### **MIGATRONIC s.r.l. IMPIANTI PER SALDATURA**

Via Dei Quadri 40, IT-20871 Vimercate (MB), Italy  
Tel. +39 039 9278093, [www.migatronicon.com](http://www.migatronicon.com)

### Norway

#### **MIGATRONIC NORGE AS**

Industriveien 6, N-3300 Hokksund, Norway  
Tel. +47 32 25 69 00, [www.migatronicon.com](http://www.migatronicon.com)

### Czech Republic

#### **MIGATRONIC CZ a.s.**

Tolstého 451, CZ-415 03 Teplice 3, Czech Republic  
Tel. +420 411 135 600, [www.migatronicon.com](http://www.migatronicon.com)

### Holland

#### **MIGATRONIC NEDERLAND B.V.**

Ericssonstraat 2, NL-5121 ML Rijen, Holland  
Tel. +31 (0)161-747840, [www.migatronicon.com](http://www.migatronicon.com)

### Sweden

#### **MIGATRONIC SVETSMASKINER AB**

Näås Fabriker, Box 5015,S-448 50 Tollerød, Sweden  
Tel. +46 031 44 00 45, [www.migatronicon.com](http://www.migatronicon.com)

### Germany

#### **MIGATRONIC SCHWEISSMASCHINEN GMBH**

Sandusweg 12, D-35435 WETTENBERG-LAUNSBACH, Germany  
Tel. +49 0641/98284-0, [www.migatronicon.com](http://www.migatronicon.com)

### Hungary

#### **MIGATRONIC KERESKEDELMI KFT.**

Futó utca 37. 6. emelet, H-1082 Budapest, Hungary  
Tel. +36 70 630 0604 [www.migatronicon.com](http://www.migatronicon.com)

## MIGATRONIC ASIA:

### India

#### **MIGATRONIC INDIA PRIVATE LTD.**

No.22 & 39/20H Sowri Street,  
IN-Alandur, Chennai – 600 016, India  
Tel. +91 44 2233 0074 [www.migatronicon.com](http://www.migatronicon.com)